

GIADA VERTICAL

POLISHED STAINLESS STEEL



Material: Polished Stainless Steel

Material:

- Horizontal collectors in polished stainless steel with \varnothing of 38 mm.
- Vertical heating elements in polished stainless steel with \varnothing of 18 mm.

Fixing kit:

- Brackets
- Air vent
- Hexagonal tool
- Plugs and screws for mounting suitable for use on compact or hollow brick walls
- User notice

Packaging:

The radiator is protected by a recycle film in polyethylene and with a box in recycle carton. User notice included.

Features:

It is totally made in stainless steel with an unalterable finishing guaranteed during the years.

Accessories and spare parts:

See page 121



P. max: 8 bar	Available for central heating systems
T. max: 95 °C	
Connections: 2 x 1/2" gas - 1 x 1/8" gas for air vent	

ACCESSORIES

	<p>KIT 2 HOOKS POLISHED STAINLESS STEEL SVR</p> <p>Price € 99,50 Art. Nr. 5991990010037</p>
--	--

	<p>ELEGANT SQUARE VALVE KIT WITH THERMOSTATIC HEAD</p>
--	---

Accessories and spare parts - see page 121

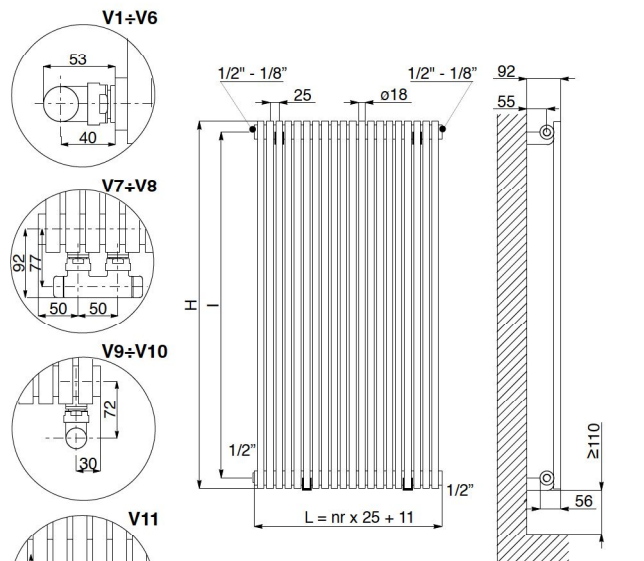

Measures for valves type "Elegant" Cordivari

LEGEND	
	In
	Out
	Air Vent
	H Height
	Connection Lenght=20 - Height=15
	Blind
	L Lenght

STANDARD CONNECTIONS

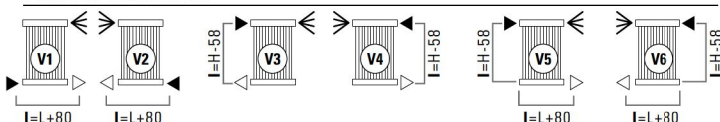

SPECIAL CONNECTIONS (Surcharge € 42,00)

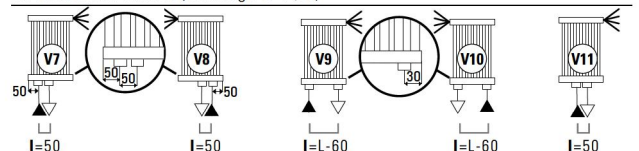

Always specify the kind of connection needed when ordering (from V1 to V11). Except two-way pipe connection.

HEIGHT H [mm]	600	800	1000	1200	1400	1600	1800	1900	2000	2200	2300
Therm. output per el. Δt = 50 °C [Watt]	16	21,3	26,6	31,6	36,6	41,3	45,9	48,4	50,3	54,2	56,6
Weight per element [kg]	0,377	0,477	0,576	0,676	0,775	0,875	0,974	1,024	1,074	1,173	1,223
Element capacity [lt]	0,186	0,225	0,263	0,301	0,339	0,377	0,416	0,435	0,454	0,492	0,511
Exponent n	1,329	1,324	1,318	1,312	1,307	1,301	1,295	1,291	1,289	1,284	1,280
Centres I [mm] (V3-V4 only)	542	742	942	1142	1342	1542	1742	1842	1942	2142	2242

Lenght L [mm]	N° El. (*)	Watt thermal output Δt=50°C										75/65/20°C (Δt=50°C)		
		W	W	W	W	W	W	W	W	W	W	W	W	W
136	5	80	107	133	158	183	207	230	242	252	271	283	340,0	347,0
		297,0	324,0	326,0	328,0	329,0	333,0	339,0	342,0	343,0	346,0	346,0	347,0	0,4402*Δt
161	6	96	128	160	190	220	248	275	290	302	325	340	327,0	358,0
		327,0	358,0	363,0	370,0	370,0	376,0	385,0	390,0	392,0	390,0	399,0	0,5282*Δt	0,7190*Δt
186	7	112	149	186	221	256	289	321	339	352	379	396	357,0	392,0
		357,0	392,0	400,0	406,0	411,0	419,0	431,0	438,0	441,0	448,0	451,0	0,6163*Δt	0,8389*Δt
211	8	128	170	213	253	293	330	367	387	402	434	453	387,0	426,0
		387,0	426,0	437,0	445,0	452,0	462,0	477,0	486,0	490,0	499,0	503,0	0,7043*Δt	0,9587*Δt
236	9	144	192	239	284	329	372	413	436	453	488	509	417,0	460,0
		417,0	460,0	474,0	484,0	493,0	505,0	523,0	534,0	539,0	550,0	555,0	0,7923*Δt	1,0786*Δt
261	10	160	213	266	316	366	413	459	484	503	542	566	447,0	494,0
		447,0	494,0	511,0	523,0	534,0	548,0	569,0	582,0	588,0	601,0	607,0	0,8804*Δt	1,1984*Δt
286	11	176	234	293	348	403	454	505	532	553	596	623	477,0	528,0
		477,0	528,0	548,0	562,0	575,0	591,0	615,0	630,0	637,0	656,0	659,0	0,9684*Δt	1,3182*Δt
311	12	192	256	319	379	439	496	551	581	604	650	679	507,0	562,0
		507,0	562,0	585,0	601,0	616,0	634,0	661,0	678,0	686,0	703,0	711,0	1,0564*Δt	1,4381*Δt
336	13	208	277	346	411	476	537	597	629	654	705	736	537,0	596,0
		537,0	596,0	622,0	640,0	657,0	677,0	707,0	726,0	735,0	754,0	763,0	1,1445*Δt	1,5579*Δt
361	14	224	298	372	442	512	578	643	678	704	759	792	567,0	630,0
		567,0	630,0	659,0	679,0	698,0	720,0	753,0	774,0	784,0	805,0	815,0	1,2325*Δt	1,6778*Δt
386	15	240	320	399	474	549	620	689	726	755	813	849	597,0	664,0
		597,0	664,0	696,0	718,0	739,0	763,0	799,0	822,0	833,0	856,0	867,0	1,3205*Δt	1,7976*Δt
411	16	256	341	426	506	586	661	734	774	805	867	906	627,0	698,0
		627,0	698,0	733,0	757,0	780,0	806,0	845,0	870,0	882,0	907,0	919,0	1,4086*Δt	1,9174*Δt
436	17	272	362	452	537	622	702	780	823	855	921	962	657,0	732,0
		657,0	732,0	770,0	796,0	821,0	849,0	891,0	918,0	931,0	958,0	971,0	1,4966*Δt	2,0373*Δt
461	18	288	383	479	569	659	743	826	871	905	976	1019	687,0	766,0
		687,0	766,0	807,0	835,0	862,0	892,0	937,0	966,0	980,0	1,009,0	1,023,0	1,5846*Δt	2,1571*Δt
486	19	304	405	505	600	695	785	872	920	956	1,030	1,075	717,0	800,0
		717,0	800,0	844,0	874,0	903,0	935,0	983,0	1,014,0	1,029,0	1,060,0	1,075,0	1,6727*Δt	2,2770*Δt
511	20	320	426	532	632	732	826	918	968	1,006	1,084	1,132	747,0	834,0
		747,0	834,0	881,0	913,0	944,0	978,0	1,029,0	1,062,0	1,078,0	1,111,0	1,127,0	1,7607*Δt	2,3968*Δt
536	21	336	447	559	664	769	867	964	1,016	1,056	1,138	1,189	777,0	868,0
		777,0	868,0	918,0	952,0	985,0	1,021,0	1,075,0	1,110,0	1,127,0	1,162,0	1,179,0	1,8488*Δt	2,5166*Δt
561	22	352	469	585	695	805	903	1,010	1,065	1,107	1,192	1,245	807,0	902,0
		807,0	902,0	955,0	991,0	1,026,0	1,064,0	1,121,0	1,158,0	1,176,0	1,213,0	1,231,0	1,8968*Δt	2,6365*Δt
586	23	368	490	612	727	842	950	1,056	1,113	1,157	1,247	1,302	837,0	936,0
		837,0	936,0	992,0	1,030,0	1,067,0	1,107,0	1,167,0	1,206,0	1,225,0	1,264,0	1,283,0	2,0248*Δt	2,7936*Δt
611	24	384	511	639	758	878	991	1,102	1,162	1,207	1,301	1,358	867,0	970,0
		867,0	970,0	1,028,0	1,069,0	1,108,0	1,150,0	1,213,0	1,254,0	1,274,0	1,315,0	1,335,0	2,1129*Δt	2,8762*Δt
636	25	400	533	665	790	915	1,033	1,148	1,210	1,258	1,355	1,415	897,0	1,004,0
		897,0	1,004,0	1,066,0	1,108,0	1,149,0	1,193,0	1,259,0	1,302,0	1,323,0	1,366,0	1,387,0	2,2009*Δt	2,9960*Δt
661	26	416	554	692	822	952	1,074	1,193	1,258	1,308	1,409	1,472	927,0	1,038,0
		927,0	1,038,0	1,103,0	1,147,0	1,190,0	1,236,0	1,305,0	1,350,0	1,372,0	1,417,0	1,439,0	2,2889*Δt	3,1159*Δt
686	27	432	575	718	853	988	1,115	1,239	1,307	1,358	1,463	1,528	957,0	1,072,0
		957,0	1,072,0	1,140,0	1,186,0	1,231,0	1,279,0	1,351,0	1,398,0	1,421,0	1,468,0	1,491,0	2,3770*Δt	3,2357*Δt
711	28	448	596	745	885	1,025	1,156	1,285	1,355	1,408	1,518	1,585	987,0	1,106,0
		987,0	1,106,0	1,177,0	1,225,0	1,272,0	1,322,0	1,397,0	1,446,0	1,470,0	1,519,0	1,543,0	2,4650*Δt	3,3555*Δt
736	29	464	618	771	916	1,061	1,198	1,331	1,404	1,459	1,572	1,641	1,017,0	1,140,0
		1,017,0	1,140,0	1,214,0	1,264,0	1,313,0	1,365,0	1,443,0	1,494,0	1,519,0	1,570,0	1,595,0	2,5530*Δt	3,4754*Δt
761	30	480	639	798	948	1,098	1,239	1,377	1,452	1,509	1,626	1,698	1,047,0	1,174,0
		1,047,0	1,174,0	1,251,0	1,303,0	1,354,0	1,408,0	1,489,0	1,542,0	1,568,0	1,621,0	1,647,0	2,6411*Δt	3,5952*Δt
786	31	496	660	825	980	1,135	1,280	1,423	1,500	1,559	1,680	1,755	1,077,0	1,208,0
		1,077,0	1,208,0	1,288,0	1,342,0	1,395,0	1,451,0	1,535,0	1,590,0	1,617,0	1,672,0	1,699,0	2,7291*Δt	3,7151*Δt
811	32	512	682	851	1,011	1,171	1,322	1,469	1,549	1,610	1,734	1,811	1,107,0	1,242,0
		1,107,0	1,242,0	1,325,0	1,381,0	1,436,0	1,494,0	1,581,0	1,638,0	1,666,0	1,723,0	1,751,0	2,8171*Δt	3,8349*Δt
836	33	528	703	878	1,043	1,208	1,363	1,515	1,597	1,660	1,789	1,868	1,137,0	1,276,0
		1,137,0	1,276,0	1,362,0	1,420,0	1,477,0	1,537,0	1,627,0	1,686,0	1,715,0	1,774,0	1,803,0	2,9052*Δt	3,9541*Δt
861	34	544	724	904	1,074	1,244	1,404	1,561	1,646	1,710	1,843	1,924	1,167,0	1,310,0
		1,167,0	1,310,0	1,399,0	1,459,0	1,518,0	1,580,0	1,673,0	1,734,0	1,764,0	1,825,0	1,855,0	2,9932*Δt	4,0746*Δt
886	35	560	746	931	1,106	1,281	1,446	1,607	1,697	1,761	1,901	1,981	1,197,0	1,344,0
		1,197,0	1,344,0	1,436,0	1,498,0	1,559,0	1,623,0	1,719,0	1,782,0	1,813,0	1,876,0	1,907,0	3,0813*Δt	4,1944*Δt

(*) W= Watt thermal output - Other information on formulas see page 130

Other heights available on request from 400 mm to 2300 mm and lenght from 136 mm to 886 mm